

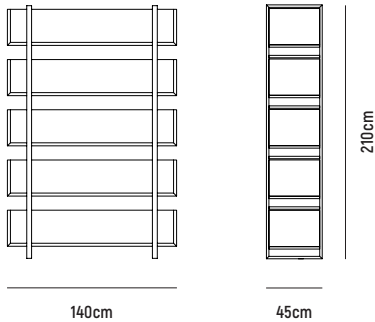

# NHI BOOKCASE



## ■ NHI BOOKCASE 140

**OVERALL DIMENSION** : W 1,400mm x D 450mm x H 2,100mm

**MATERIAL** : American Oak Veneer on MDF  
(Pictured) in Clear Polyurethane Finish (shelves) and Powder-Coated Aluminium (frame)

**ASSEMBLY** : Fully Assembled

**WARRANTY** : 3 Year Timber & Structural Warranty  
(excluding finish)

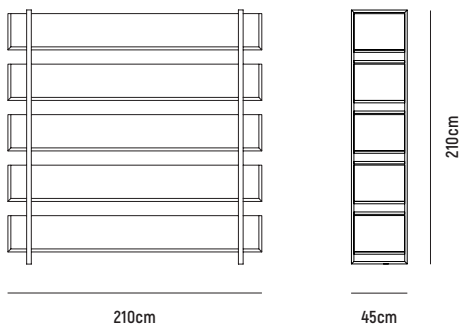

## ■ NHI BOOKCASE 210

**OVERALL DIMENSION** : W 2,100mm x D 450mm x H 2,100mm

**MATERIAL** : American Oak Veneer on MDF  
(Pictured) in Clear Polyurethane Finish (shelves) and Powder-Coated Aluminium (frame)

**ASSEMBLY** : Fully Assembled

**WARRANTY** : 3 Year Timber & Structural Warranty  
(excluding finish)

